

**BLACK+**  
**DECKER**

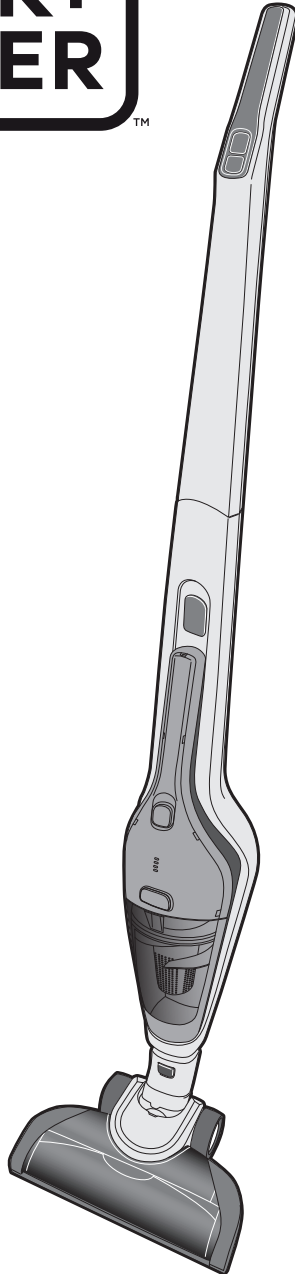

[www.blackanddecker.com.au](http://www.blackanddecker.com.au)  
[www.blackanddecker.co.nz](http://www.blackanddecker.co.nz)

**SVA320B**



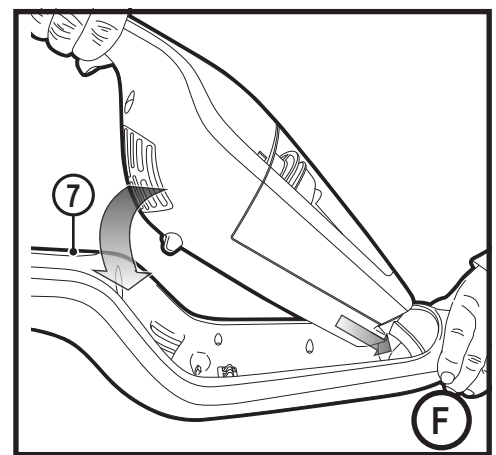
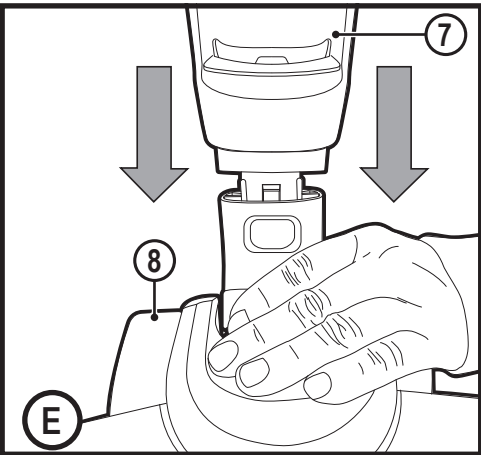
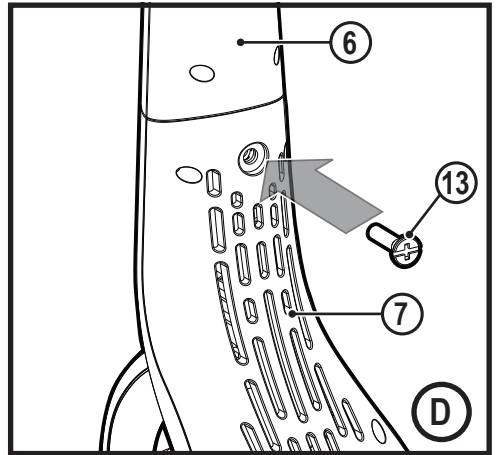
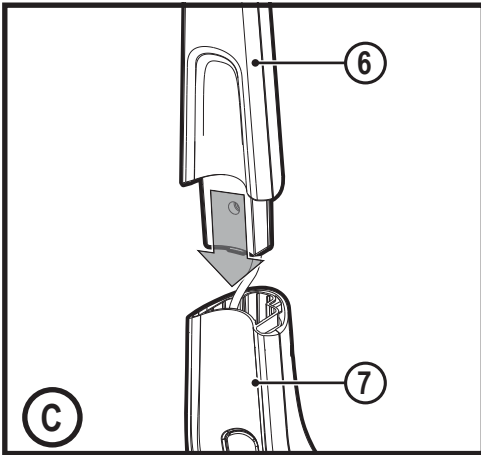
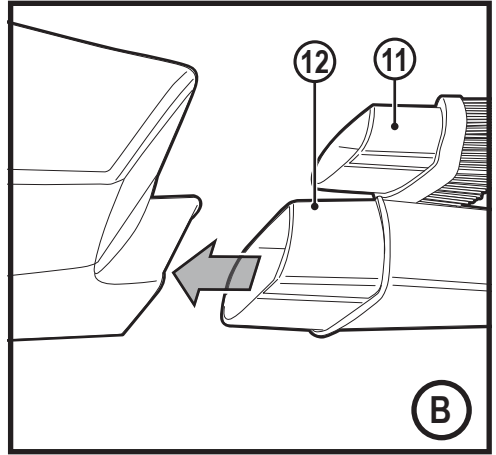
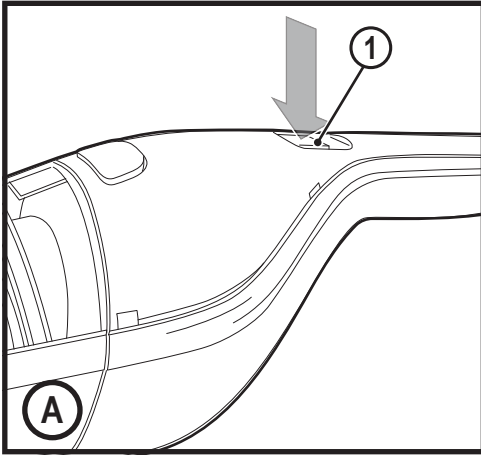

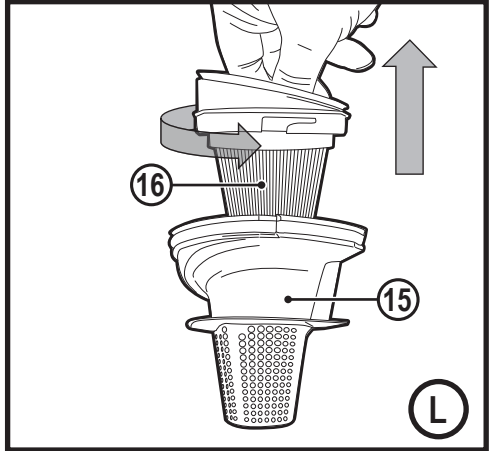
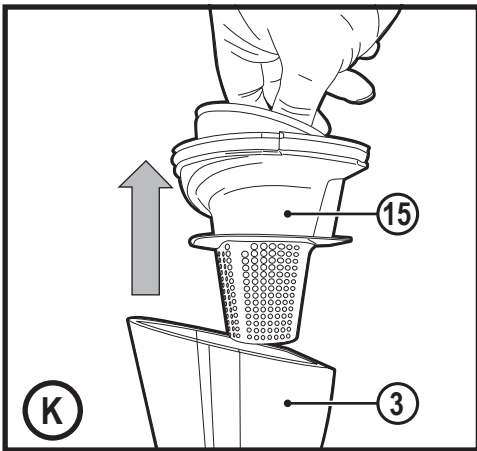
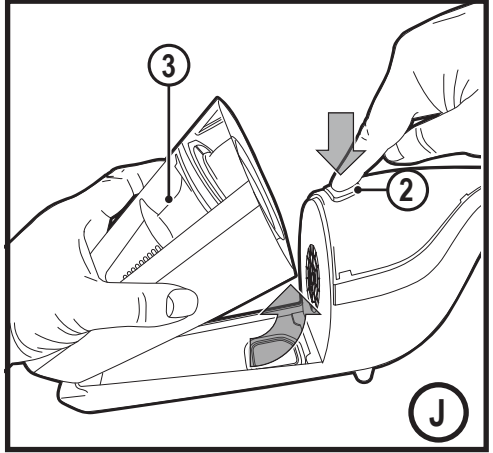
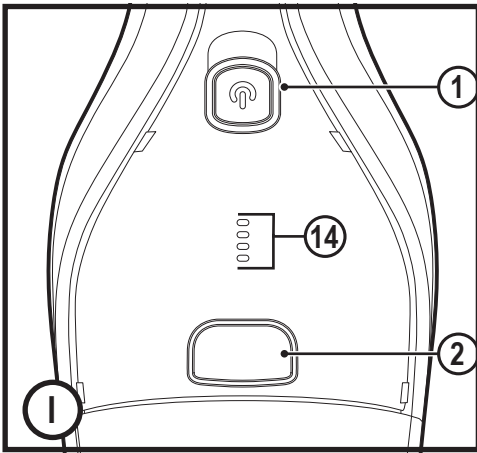
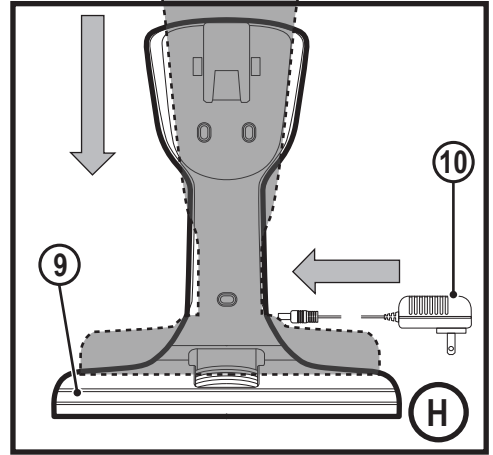
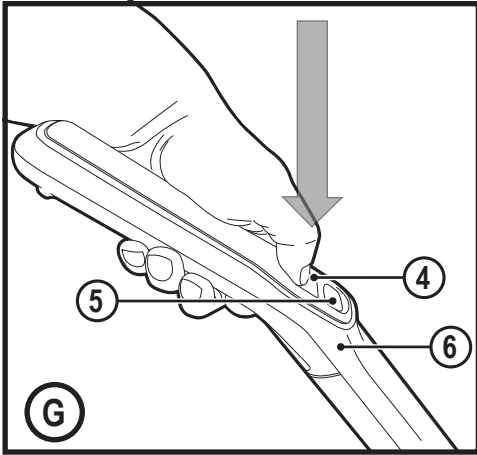

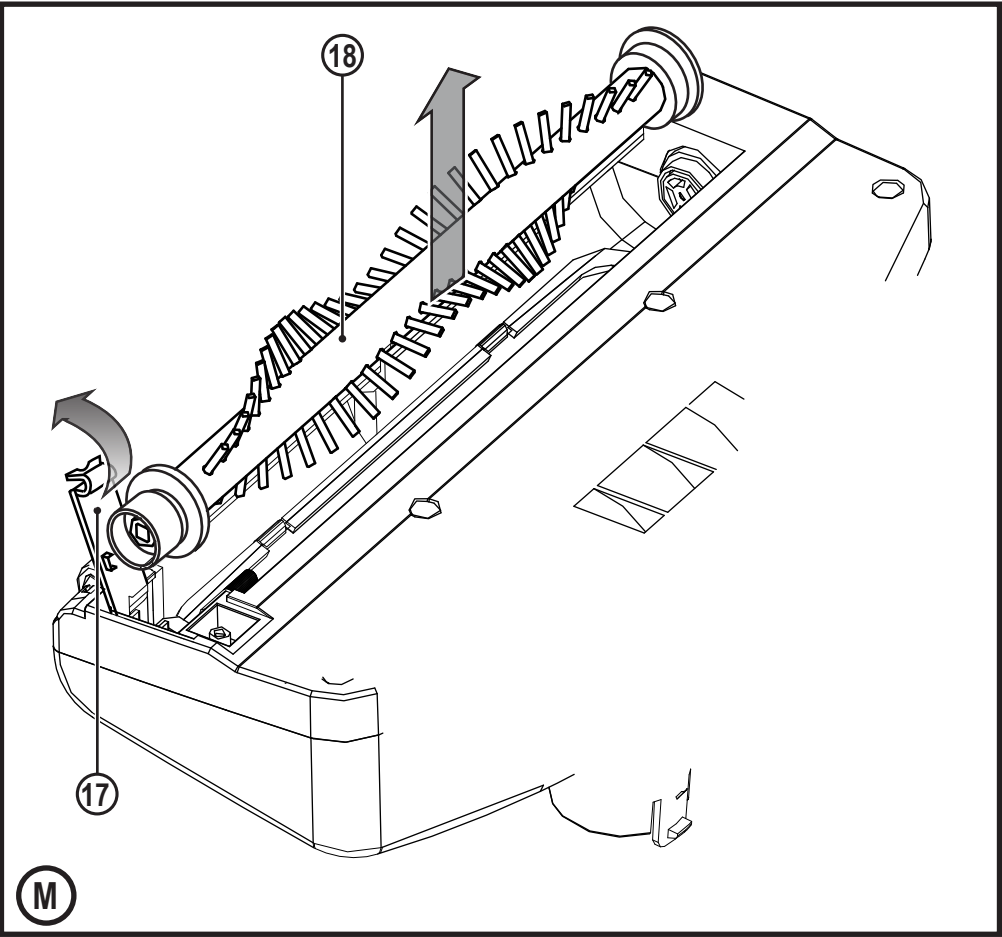
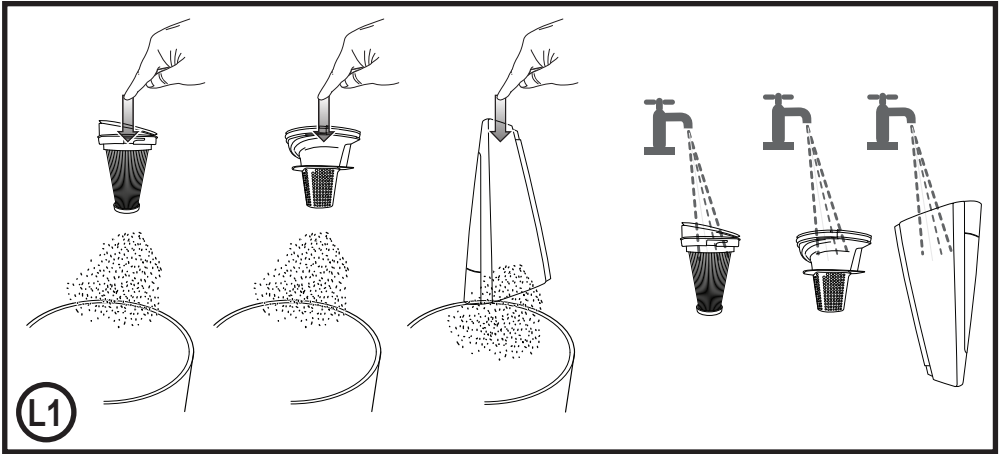

**Intended use**

Your BLACK+DECKER SVA320B 2 in 1 Stick vac has been designed for vacuum cleaning purposes. These appliances are intended for household use only.



Read all of this manual carefully before operating the appliance.

**Safety instructions****Warning! Read all safety warnings and all instructions.**

Failure to follow the warnings and instructions listed below may result in electric shock, fire and/or serious injury.



**Warning!** When using battery-powered appliances, basic safety precautions, including the following, should always be followed to reduce the risk of fire, leaking batteries, personal injury and material damage.

- ◆ Read all of this manual carefully before using the appliance.
- ◆ The intended use is described in this manual. The use of any accessory or attachment or the performance of any operation with this appliance other than those recommended in this instruction manual may present a risk of personal injury.
- ◆ Retain this manual for future reference.

**Using your appliance**

- ◆ Do not use the appliance to pick up liquids or any materials that could catch fire
- ◆ Do not use the appliance near water.
- ◆ Do not immerse the appliance in water.

- ◆ Never pull the charger lead to disconnect the charger from the socket. Keep the charger lead away from heat, oil and sharp edges.
- ◆ This appliance can be used by children aged from 8 years and above and persons with reduced physical, sensory or mental capabilities or lack of experience and knowledge if they have been given supervision or instruction concerning use of the appliance in a safe way and understand the hazards involved. Children shall not play with the appliance. Cleaning and user maintenance shall not be made by children without supervision.

**Inspection and repairs**

Before use, check the appliance for damaged or defective parts. Check for breakage of parts, damage to switches and any other conditions that may affect its operation.

- ◆ Do not use the appliance if any part is damaged or defective.
- ◆ Have any damaged or defective parts repaired or replaced by an authorized repair agent.
- ◆ Regularly check the charger lead for damage. Replace the charger if the lead is damaged or defective.
- ◆ Never attempt to remove or replace any parts other than those specified in this manual.

**Additional safety instructions****After use**

- ◆ Unplug the charger before cleaning the charger or charging base.
- ◆ When not in use, the appliance should be stored in a dry place.

- ◆ Children should not have access to stored appliances.

## Residual risks

Additional residual risks may arise when using the tool which may not be included in the enclosed safety warnings. These risks can arise from misuse, prolonged use etc. Even with the application of the relevant safety regulations and the implementation of safety devices, certain residual risks can not be avoided.

These include:

- ◆ Injuries caused by touching any rotating/moving parts.
- ◆ Injuries caused when changing any parts, blades or accessories.
- ◆ Injuries caused by prolonged use of a tool. When using any tool for prolonged periods ensure you take regular breaks.
- ◆ Impairment of hearing.
- ◆ Health hazards caused by breathing dust developed when using your tool (example:- working with wood, especially oak, beech and MDF.)

## Batteries and chargers

### Batteries

- ◆ Never attempt to open for any reason.
- ◆ Do not expose the battery to water.
- ◆ Do not expose the battery to heat.
- ◆ Do not store in locations where the temperature may exceed 40°C.
- ◆ Charge only at ambient temperatures between 10°C and 40°C.
- ◆ Charge only using the charger provided with the appliance/tool. Using the wrong charger could result in an electric shock or overheating of the battery.

- ◆ When disposing of batteries, follow the instructions given in the section "Protecting the environment".
- ◆ Do not damage/deform the battery pack either by puncture or impact, as this may create a risk of injury and fire
- ◆ Do not charge damaged batteries.
- ◆ Under extreme conditions, battery leakage may occur. When you notice liquid on the batteries carefully wipe the liquid off using a cloth. Avoid skin contact.
- ◆ In case of skin or eye contact, follow the instructions below.

**Warning!** The battery fluid may cause personal injury or damage to property. In case of skin contact, immediately rinse with water. If redness, pain or irritation occurs seek medical attention. In case of eye contact, rinse immediately with clean water and seek medical attention.

### Chargers

Your charger has been designed for a specific voltage. Always check that the mains voltage corresponds to the voltage on the rating plate.

**Warning!** Never attempt to replace the charger unit with a regular mains plug.

- ◆ Use your BLACK+DECKER charger only to charge the battery in the appliance with which it was supplied. Other batteries could burst, causing personal injury and damage.
- ◆ Never attempt to charge non-rechargeable batteries.
- ◆ If the supply cord is damaged, it must be replaced by the manufacturer or an authorised BLACK+DECKER Service Centre in order to avoid a hazard.
- ◆ Do not expose the charger to water.
- ◆ Do not open the charger.
- ◆ Do not probe the charger.

- ◆ The appliance/battery must be placed in a well ventilated area when charging.

## Electrical safety

Your charger has been designed for a specific voltage. Always check that the mains voltage corresponds to the voltage on the rating plate. Never attempt to replace the charger unit with a regular mains plug.

## Symbols on the charger



Read all of this manual carefully before using the appliance



This tool is double insulated; therefore no earth wire is required. Always check that the power supply corresponds to the voltage on the rating plate.



Short circuit proof safety isolating transformer. The mains supply is electrically separated from the transformer output.



SMPS



Indication of polarity.



The charging base is intended for indoor use only.

### Labels on appliance

The following symbols appear on this appliance along with the date code



Read all of this manual carefully before using the appliance



J0D-S-150050AU

## Features

This tool includes some or all of the following features.

1. On/off power switch
2. Dust bowl release button
3. Dust bowl
4. Chassis on/off power switch
5. Brush control switch
6. Upper handle
7. Main chassis

- 7a. Chassis release button
8. Floor head
9. Floor charging base
- 9a. Tool storage
10. Charger
11. Brush tool accessory
12. Crevice tool accessory

## Use

### Switching on and off (Fig. A)

- ◆ To switch on, press the on/off switch (1) located on the handle of the main unit (1), or alternatively on the chassis handle (4).
- ◆ To switch off, press the on/off switch (1) or (4).

### Using Accessories (Fig. B)

- ◆ The appliance is supplied with a brush tool (11) and a crevice tool (12).
- ◆ Fit the chosen accessory into the front of the appliance as shown in Figure B.

### Fitting the upper handle to the main chassis (Fig. C, D)

- ◆ The stick vac chassis is supplied in 2 parts, the upper handle (6) and the lower chassis (7), but they are connected by a wire.
- ◆ Slide the upper handle (6) into the main chassis (7) as shown in figure C
- ◆ Ensure the wire is not trapped.
- ◆ Secure with retaining screw (13) as shown in figure D

### Fitting the floor head to the Chassis (Fig. E)

- ◆ Slide the main chassis (7) into the floor head (8) until an audible click is heard, as shown in figure E

### Fitting the vacuum to the Chassis (Fig. F, G)

- ◆ Slide the vacuum, nozzle first, into the chassis (7) until an audible 'click' is heard as shown in figure .
- ◆ To release the vacuum from the chassis press the chassis release button (7a) and lift clear.
- ◆ The appliance can now be operated via the on/off button (4) on the handle (6). This also allows you to utilise the beater bars via the 'brush on' control (5) as shown in figure G

### Charging (Fig. H)

- ◆ The charging base (9) will need to be securely fastened to a wall.

**Note:** Ensure that appropriate fixings for the type of wall surface are used.



- ◆ Place the appliance into the charging base (9) as shown in figure H .
- ◆ Plug the charger (10) into the charging base (9)
- ◆ Plug the charger (10) into an electrical outlet.
- ◆ Switch the electrical outlet on. The LED charging indicator (14) will illuminate (Fig. I).

## Cleaning the filters (Fig. J, K,L)

- ◆ Press the dust bowl release button (2) and lift out the dust bowl (3) (Fig.J)
- ◆ Lift the filter assembly (15) from the dust bowl (3) (Fig.K)
- ◆ Empty the dust bowl by lightly shaking over a dustbin.
- ◆ The filter (16) can now be removed from the pre filter (15) by rotating anti clockwise figure L.
- ◆ Tap to empty excess dust and detritus from the filter , pre filter and dust-bowl figure L
- ◆ Rinse out the dust-bowl with warm soapy water figure L1
- ◆ Wash the filters with warm soapy water figure L
- ◆ Make sure the filters and dust-bowl are dry .
- ◆ Refit the filters into the appliance
- ◆ Close the dust-bowl. Make sure the release latch (2) clicks into place.

From time to time wipe the appliance with a damp cloth. Do not use any abrasive or solvent-based cleaner. Do not immerse the appliance in water.

## Removing and cleaning the beater bar (Fig. M)

- ◆ Pinch and lift the plastic tab on the pivoting clip (17) away from the floor head
- ◆ Lift the beater bar (18) out of the floor head
- ◆ Ensure the beater bar and pivoting clip are replaced before using the vacuum.

## Maintenance

Your BLACK+DECKER cordless appliance has been designed to operate over a long period of time with a minimum of maintenance. Continuous satisfactory operation depends upon proper tool care and regular cleaning.

**Warning!** Before performing any maintenance on cordless appliances:

- ◆ Run the battery down completely if it is integral and then switch off.
- ◆ Unplug the charger before cleaning it. Your charger does not require any maintenance apart from regular cleaning.
- ◆ Regularly clean the ventilation slots in your appliance/ charger using a soft brush or dry cloth.
- ◆ Regularly clean the motor housing using a damp cloth. Do not use any abrasive or solvent-based cleaner.

## Replacing the filters

The filters should be replaced every 6 to 9 months and when ever worn or damaged. Replacement filters are available from your BLACK+DECKER dealer (cat. no: SVF11).

- ◆ Remove the old filters as described above
- ◆ Fit the new filters as described above

## Protecting the environment



Separate collection. Products and batteries marked with this symbol must not be disposed of with normal household waste.

Products and batteries contain materials that can be recovered or recycled reducing the demand for raw materials. Please recycle electrical products and batteries according to local provisions. Further information is available at [www.2helpU.com](http://www.2helpU.com)

## Technical Data

	SVA320B
Voltage	10.8V
Watt hours	36Wh
Weight	2.1Kg
Charger	JOD-S-150050AU
Input Voltage (V <sub>ac</sub> )	100-240
Output Voltage (V)	15
Current (mA)	500
Approx charge time (h)	4

**Australia & New Zealand**

Stanley Black & Decker

[www.blackanddecker.com.au](http://www.blackanddecker.com.au)

[www.blackanddecker.co.nz](http://www.blackanddecker.co.nz)

Tel. 1800 338 002 (Aust) or Tel. 0800 339 258 (NZ)



